

FDM Models Reduce Time to Market for New Spoonable Zero-Calorie Sweetener

"FDM models play a critical role in our design process by allowing customers to evaluate a 3-Dimensional model to take the guesswork out of the design process."

— Stephen Kocis, Creative Design Services manager, Silgan Plastics

Silgan Plastics is a leader in the design and manufacture of plastic bottles, jars, tubes, caps and fitments for the food, health care, personal care and household markets. Silgan Plastics is an operating company of Silgan Holdings, a leading manufacturer of consumer goods packaging products with annual net sales of \$3.1 billion in 2010.

When Cargill made plans to introduce a spoonable version of its Truvia™ zero-calorie natural sweetener, it asked the Silgan Plastics' Creative Design Services group to develop an innovative container. Cargill was looking for a 9.8 ounce rigid, recyclable container that would allow consumers to conveniently dip, spoon or sprinkle Truvia in quantities of their choosing. The package needed to fit the average retail shelf and be sufficiently distinctive and attractive so that consumers would want to display it on their table or countertop.

The Silgan Plastics design team evaluated dozens of possible alternatives using sketchpads and design software and finally decided on the 10 best design concepts. In the past, Silgan Plastics would have hired a subcontractor to fabricate plastic models from a thermoformed mold or machine them from a suitable material. The cost for each prototype would have been about \$750 and the leadtime to produce all 10 prototypes would have been roughly one month.

"Our customers want to get their products to market quickly and begin generating revenues," said Stephen Kocis, Creative Design Services Manager for Silgan Plastics. "We invested in three Stratasys Fused Deposition Modeling (FDM®) machines because FDM prototypes provide the accuracy and detail needed for evaluation by customers of alternative concepts," Kocis said. "FDM machines are also affordable and can easily be used in an office environment."

Silgan built FDM prototypes of the 10 design concepts over a 48-hour period at a cost of \$30 in materials and \$270 in FDM machine time and overhead for each. The Truvia team visited the Silgan Plastics design center where they viewed and handled the prototypes. The team narrowed their selection to a few designs and suggested refinements. "FDM models make it much easier to visualize and evaluate the functionality and ergonomics of a proposed design," Kocis said.

Silgan Plastics revised the designs and made new FDM prototypes. Tweaking and discussions continued until the Truvia team selected the final package. As the design

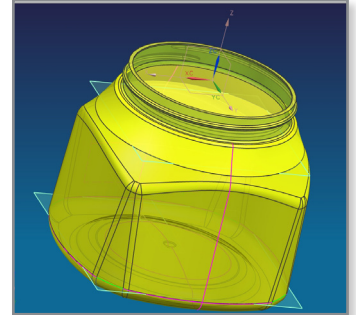

Silgan Plastics designers created a series of concept designs for the Truvia package within our design/engineering software.



The Truvia package was designed to be attractive enough that consumers would want to display it on their countertop.

How Did FDM Compare to Traditional Prototyping Methods for Silgan Plastics?

Method	Cost (Qty. 1)	Time (Qty. 10)
Machine pattern and thermoform prototype	\$750	30 days
FDM prototype	\$300	2 days
SAVINGS	\$450 (60%)	28 days (93%)

was finalized for production, Silgan Plastics used the FDM models to check container size and fill levels, evaluate decorating methods, validate distortion in the shrink sleeve graphics and evaluate the moldability of the design.

Consumers and retailers have responded well to the new package. At fabfindfoodie.com, one reviewer said: "I love the new Truvia spoonable container. It's so handy to just pop the top and grab a spoonful of Truvia for my morning coffee or a glass of iced tea in the afternoon. Now instead of having to open a packet every time, all I need is a spoon." Kocis concluded: "FDM models take the guesswork out of the design process."

For more information about Stratasys systems, materials and applications, call **888.480.3548** or visit www.stratasys.com

Stratasys Incorporated

7665 Commerce Way
Eden Prairie, MN 55344
+1 888 480 3548 (US Toll Free)
+1 952 937 3000 (Intl)
+1 952 937 0070 (Fax)
www.stratasys.com
info@stratasys.com

Stratasys GmbH

Weismüllerstrasse 27
60314 Frankfurt am Main
Germany
+49 69 420 994 30 (Tel)
+49 69 420 994 333 (Fax)
www.stratasys.com
europa@stratasys.com

ISO 9001:2008 Certified

©2011 Stratasys Inc. All rights reserved. Stratasys, Fortus, Dimension, uPrint and FDM are registered trademarks and Real Parts, Fortus 360mc, Fortus 400mc, Fortus 900mc, Finishing Touch, Insight, Control Center and FDM TEAM are trademarks of Stratasys Inc., registered in the United States and other countries. *ULTEM 9085 is a trademark of SABIC Innovative Plastics IP BV. All other trademarks are the property of their respective owners. Product specifications subject to change without notice. Printed in the USA. SSYS-CS-SilganPlastics-05-11

